



U.S. Department
of Transportation
**Federal Highway
Administration**

1200 New Jersey Ave., SE
Washington, D.C. 20590

May 4, 2020

In Reply Refer To:
HSST-1/ WZ-389

Mr. Chuck Mettler
Plastic Safety Systems, Inc.
2444 Baldwin Road
Cleveland, OH 44104
USA

Dear Mr. Mettler:

This letter is in response to your January 14, 2020 request for the Federal Highway Administration (FHWA) to review a roadside safety device, hardware, or system for eligibility for reimbursement under the Federal-aid highway program. This FHWA letter of eligibility is assigned FHWA control number WZ-389 and is valid until a subsequent letter is issued by FHWA that expressly references this device.

Decision

The following device is eligible within the length-of-need, with details provided in the form which is attached as an integral part of this letter:

- PSS Anchor Mast Type III Barricade

Scope of this Letter

To be found eligible for Federal-aid funding, new roadside safety devices should meet the crash test and evaluation criteria contained in the American Association of State Highway and Transportation Officials' (AASHTO) Manual for Assessing Safety Hardware (MASH). However, the FHWA, the Department of Transportation, and the United States Government do not regulate the manufacture of roadside safety devices. Eligibility for reimbursement under the Federal-aid highway program does not establish approval, certification or endorsement of the device for any particular purpose or use.

This letter is not a determination by the FHWA, the Department of Transportation, or the United States Government that a vehicle crash involving the device will result in any particular outcome, nor is it a guarantee of the in-service performance of this device. Proper manufacturing, installation, and maintenance are required in order for this device to function as tested.

This finding of eligibility is limited to the crashworthiness of the system and does not cover other structural features, nor conformity with the Manual on Uniform Traffic Control Devices.

Eligibility for Reimbursement

Based solely on a review of crash test results and certifications submitted by the manufacturer, and the crash test laboratory, FHWA agrees that the device described herein meets the crash test and evaluation criteria of the AASHTO's MASH. Therefore, the device is eligible for reimbursement under the Federal-aid highway program if installed under the range of tested conditions.

Name of system: PSS Anchor Mast Type III Barricade
Type of system: Work Zone Type III Barricade
Test Level: MASH Test Level 3 (TL3)
Testing conducted by: Texas A&M Transportation Institute.
Date of request: January 14, 2020

FHWA concurs with the recommendation of the accredited crash testing laboratory on the attached form.

Full Description of the Eligible Device

The device and supporting documentation, including reports of the crash tests or other testing done, videos of any crash testing, and/or drawings of the device, are described in the attached form.

Notice

This eligibility letter is issued for the subject device as tested. Modifications made to the device are not covered by this letter. Any modifications to this device should be submitted to the user (i.e., state DOT) as per their requirements.

You are expected to supply potential users with sufficient information on design, installation and maintenance requirements to ensure proper performance.

You are expected to certify to potential users that the hardware furnished has the same chemistry, mechanical properties, and geometry as that submitted for review, and that it will meet the test and evaluation criteria of AASHTO's MASH.

Issuance of this letter does not convey property rights of any sort or any exclusive privilege. This letter is based on the premise that information and reports submitted by you are accurate and correct. We reserve the right to modify or revoke this letter if: (1) there are any inaccuracies in the information submitted in support of your request for this letter, (2) the qualification testing was flawed, (3) in-service performance or other information reveals safety problems, (4) the system is significantly different from the version that was crash tested, or (5) any other information indicates that the letter was issued in error or otherwise does not reflect full and complete information about the crashworthiness of the system.

Standard Provisions

- To prevent misunderstanding by others, this letter of eligibility designated as FHWA control number WZ-389 shall not be reproduced except in full. This letter and the test documentation upon which it is based are public information. All such letters and documentation may be reviewed upon request.
- This letter shall not be construed as authorization or consent by the FHWA to use, manufacture, or sell any patented system for which the applicant is not the patent holder.
- This FHWA eligibility letter is not an expression of any Agency view, position, or determination of validity, scope, or ownership of any intellectual property rights to a specific device or design. Further, this letter does not impute any distribution or licensing rights to the requester. This FHWA eligibility letter determination is made based solely on the crash-testing information submitted by the requester. The FHWA reserves the right to review and revoke an earlier eligibility determination after receipt of subsequent information related to crash testing.

Sincerely,



Michael S. Griffith
Director, Office of Safety Technologies
Office of Safety

Enclosures

Request for Federal Aid Reimbursement Eligibility of Highway Safety Hardware

Submitter	Date of Request:	January 14, 2020	<input checked="" type="radio"/> New <input type="radio"/> Resubmission
	Name:	Chuck Mettler	
	Company:	Plastic Safety Systems, Inc., dba PSS.	
	Address:	2444 Baldwin Road, Cleveland, OH 44104	
	Country:	USA	
	To:	Michael S. Griffith, Director FHWA, Office of Safety Technologies	

I request the following devices be considered eligible for reimbursement under the Federal-aid highway program.

Device & Testing Criterion - Enter from right to left starting with Test Level

1-1-1

System Type	Submission Type	Device Name / Variant	Testing Criterion	Test Level
'WZ': Crash Worthy Work Zone Traffic Control Devices	<input checked="" type="radio"/> Physical Crash Testing <input type="radio"/> Engineering Analysis	PSS Anchor® Mast® Type III Barricade	AASHTO MASH	TL3

By submitting this request for review and evaluation by the Federal Highway Administration, I certify that the product(s) was (were) tested in conformity with the AASHTO Manual for Assessing Safety Hardware and that the evaluation results meet the appropriate evaluation criteria in the MASH.

Individual or Organization responsible for the product:

Contact Name:	Chuck Mettler	Same as Submitter <input checked="" type="checkbox"/>
Company Name:	Plastic Safety Systems, Inc., dba PSS.	Same as Submitter <input checked="" type="checkbox"/>
Address:	2444 Baldwin Road, Cleveland, OH 44104	Same as Submitter <input checked="" type="checkbox"/>
Country:	USA	Same as Submitter <input checked="" type="checkbox"/>

Enter below all disclosures of financial interests as required by the FHWA 'Federal-Aid Reimbursement Eligibility Process for Safety Hardware Devices' document.

Texas A&M Transportation Institute (TTI) was contracted by Plastic Safety Systems, Inc. dba PSS (PSS) to perform full-scale crash testing of the PSS Anchor® Mast® Type III Barricade. There are no shared financial interests in the PSS Anchor® Mast® Type III Barricade by TTI, or between PSS and TTI, other than costs involved in the actual crash tests and reports for this submission to FHWA.

PRODUCT DESCRIPTION

New Hardware or Significant Modification
 Modification to Existing Hardware

The tested traffic control device was a proprietary PSS Anchor® Mast® Type III Barricade manufactured by Plastic Safety Systems, Inc. dba PSS. The PSS Anchor® Mast® Type III Barricade system was comprised of three 96-inch long horizontal wave boards supported by a pair of Mast® upright posts and Anchor® base feet spaced 76 inches apart. The tops of the three wave boards were 20.5 inches, 40.5 inches, and 60.5 inches above the pavement. The bases, up-rights, and wave boards were constructed of HDPE material.

CRASH TESTING

By signature below, the Engineer affiliated with the testing laboratory, agrees in support of this submission that all of the critical and relevant crash tests for this device listed above were conducted to meet the MASH test criteria. The Engineer has determined that no other crash tests are necessary to determine the device meets the MASH criteria.

Engineer Name:		
Engineer Signature:	D. Lance Bullard, Jr.	Digitally signed by D. Lance Bullard, Jr. Date: 2020.01.15 12:41:00 -06'00'
Address:	3100 SH 47, Bldg 7091, Byran, Texas 77807	Same as Submitter <input type="checkbox"/>
	TTL-TAMU 3135, College Station, TX 77843-3135	
Country:	USA	Same as Submitter <input type="checkbox"/>

A brief description of each crash test and its result:

Required Test Number	Narrative Description	Evaluation Results
3-70 (1100C)	MASH states that Test 3-70 for small vehicles is considered optional for work-zone traffic control devices weighing less than 220 lb, because velocity changes during low-speed impacts with free-standing, lightweight features will be within acceptable limits. The PSS Anchor® Mast® Type III Barricade traffic control device weighed approximately 35 pounds each, exclusive of the sandbags. Therefore, MASH Test 3-70 was not performed on this traffic control device.	Non-Critical, not conducted

Required Test Number	Narrative Description	Evaluation Results
3-71 (1100C)	<p>The results of test 690900-PSS21 are found in TTI Test Report number 690900-PSS19-21. The test vehicle was traveling at an impact speed of 60.3 mi/h when it contacted the barricade 14 inches from vehicle centerline toward passenger's side aligned with centerline of barricade at an impact angle of 90°. The supports pulled out of the bases. The wave boards and supports remained together and came to rest 67 ft downstream and 12.5 ft right of the original position. The right base came to rest 21 ft downstream and 4 ft right of the point of impact. The left base came to rest 15 ft downstream of the point of impact. The air dam was damaged and there were 3 small dents in the hood, one at the front edge (4 inches x 2.5 inches x 0.25 inch deep), a second at the right front corner (7 inches x 9 inches x 0.2 inch deep), and a third at the rear edge right of centerline (2 inches x 2 inches x 0.2 inch deep). Maximum exterior crush to the vehicle was 0.25 inches in the front plane at the right quarter point at hood height. No occupant compartment deformation or intrusion was observed. The device performed acceptably for MASH test 3-71.</p> <p>The results of test 690900-PSS20 are found in TTI Test Report number 690900-PSS19-21. The test vehicle was traveling at an impact speed of 62.8 mi/h when it contacted the barricade 14 inches from the vehicle centerline toward driver's side aligned with centerline of the left barricade post (the remaining barricade was to the right), at an impact angle of 0°. The supports pulled out of the bases and the bases remained near the impact point. The wave boards and supports remained together and came to rest 95 ft downstream of the impact point and 48 ft left of centerline of the vehicle path. There were only scuff marks on the front bumper and hood. No measurable deformation or crush occurred. No occupant compartment deformation or intrusion was observed. The device performed acceptably for MASH test 3-71.</p> <p>NOTE: MASH does not require instrumentation of the vehicle when impacting lightweight, free-standing work zone traffic control devices weighing less than 220 lb, therefore the occupant risk factors were not calculated for these tests. PSS Anchor® Mast® Type III Barricade system weighed 35 lb each, exclusive of the sandbags.</p>	PASS

3-72 (2270P)	<p>MASH Test 3-72 involves a 2270P vehicle weighing 5000 lb \pm110 lb impacting the traffic control device at an impact speed of 62 mi/h \pm2.5 mi/h. Per MASH recommendations, the device was tested at critical impact angles (CIAs) of 90° \pm1.5° and 0° \pm1.5°.</p> <p>The results of test 690900-PSS19 conducted on September 13, 2019 are found in TTI Test Report number 690900-PSS19-21. The test vehicle was traveling at an impact speed of 62.3 mi/h when it contacted the first barricade at an impact angle of 0°. The vehicle was traveling at an impact speed of 61.3 mi/h and impact angle of 90° when it contacted the second barrier. Brakes on the vehicle were applied after loss of contact with the barricade, and the vehicle came to rest 315 ft downstream of the point of impact. The left base of the first barricade remained near impact, the right base came to rest 25 ft downstream of impact, and the boards and supports came to rest 150 ft downstream of the point of impact and 63 ft to the right of centerline of the vehicle impact path. The bases of the second barricade remained near impact, and the boards and supports came to rest 355 ft downstream of the point of impact and 8 ft left of centerline of the vehicle impact path. The right side of the grill was damaged, and there was a minor indentation in the bumper 12 inches to the right of centerline. The right side of the hood was deformed slightly over an area of 15 inches x 22 inches, and there was a chip in the windshield 1.5 inches in diameter. There was no measurable exterior crush to the vehicle, and no occupant compartment deformation or intrusion was noted. The device performed acceptably for MASH test 3-72 with impact angles of 0° and 90°.</p> <p>NOTE: MASH does not require instrumentation of the vehicle when impacting lightweight, freestanding work zone traffic control devices weighing less than 220 lb, therefore the occupant risk factors were not calculated for this test. The PSS Anchor® Mast® Type III Barricade system weighed 35 lb each, exclusive of the sandbags.</p>	PASS
--------------	---	------

Full Scale Crash Testing was done in compliance with MASH by the following accredited crash test laboratory (cite the laboratory's accreditation status as noted in the crash test reports.):

Laboratory Name:	Texas A&M Transportation Institute	
Laboratory Signature:	Digitally signed by Darrell L. Kuhn 'Date: 2020.01.14 16:49:56 -06'00 	
Address:	3100 SH 47, Bldg 7091, Byran, Texas 77807 TTI, TAMU 3135, College Station, TX 77843-3135	Same as Submitter <input type="checkbox"/>
Country:	USA	Same as Submitter <input type="checkbox"/>
Accreditation Certificate Number and Dates of current Accreditation period :	ISO 17025-2017 Laboratory A2LA Certificate Number: 2821.01 Valid To: April 30, 2021	

Submitter Signature*: 

Submit Form

ATTACHMENTS

Attach to this form:

- 1) Additional disclosures of related financial interest as indicated above.
- 2) A copy of the full test report, video, and a Test Data Summary Sheet for each test conducted in support of this request.
- 3) A drawing or drawings of the device(s) that conform to the Task Force-13 Drawing Specifications [Hardware Guide Drawing Standards]. For proprietary products, a single isometric line drawing is usually acceptable to illustrate the product, with detailed specifications, intended use, and contact information provided on the reverse. Additional drawings (not in TF-13 format) showing details that are relevant to understanding the dimensions and performance of the device should also be submitted to facilitate our review.

FHWA Official Business Only:

Eligibility Letter		
Number	Date	Key Words

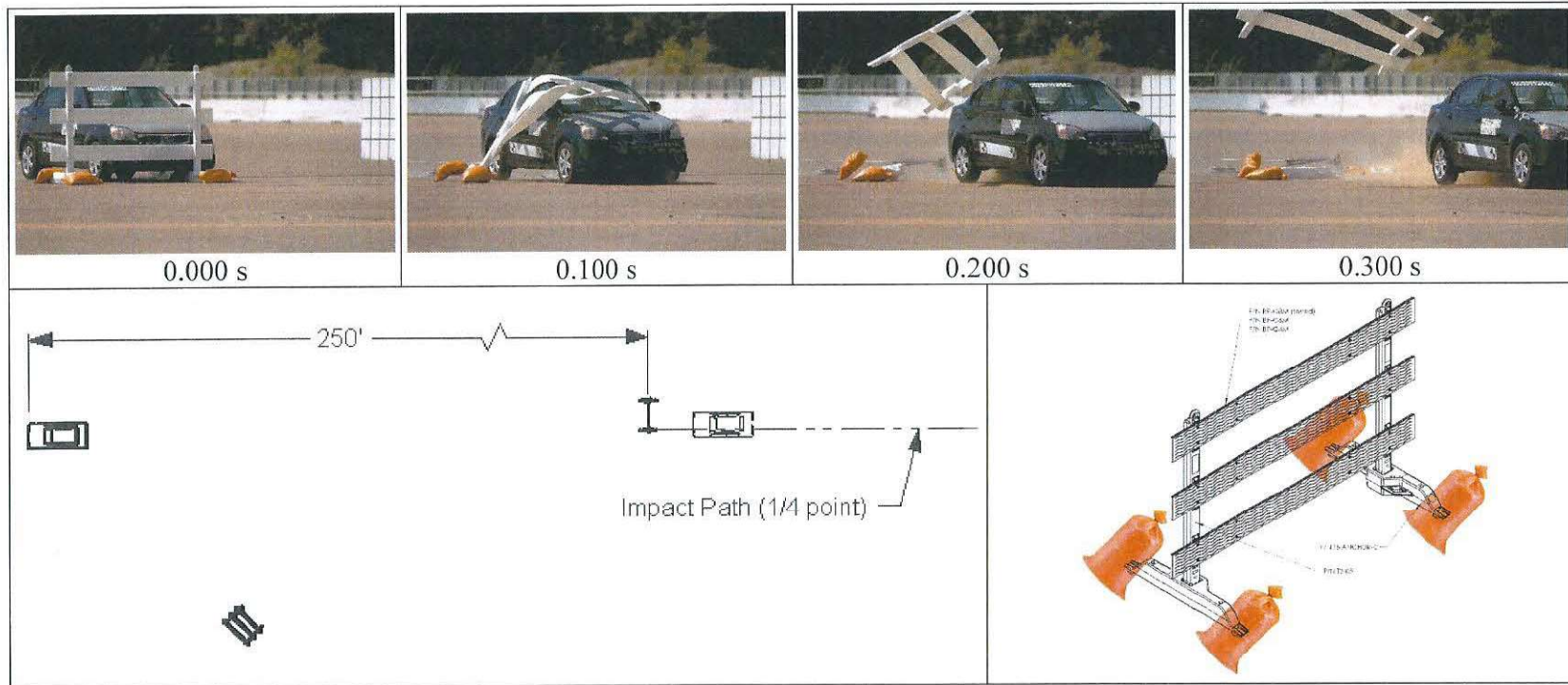

General Information

Test Agency Texas A&M Transportation Institute (TTI)
 Test Standard Test No. MASH Test 3-71 at 0°
 TTI Test No. 690900-PSS20
 Date 2019-09-13

Test Article

Type Type III Barricade
 Name PSS Anchor® Mast® Type III Barricade
 Installation Dimensions 96 inches wide x 47.6 inches long x 64.4 inches tall
 Material or Key Elements Three horizontal wave boards supported by a pair of Mast® upright posts and Anchor® base feet

Soil Type and Condition Placed on concrete surface, dry

Test Vehicle

Type/Designation 1100C
 Make and Model 2011 Kia Rio
 Curb 2455 lb
 Test Inertial 2438 lb
 Dummy 165 lb
 Gross Static 2603 lb

Impact Conditions

Speed 62.8 mi/h
 Angle 0°
 Location/Orientation 14 inches left of centerline

Kinetic Energy (KE)

Speed unobtainable
 Angle 0°

Exit Conditions

Post-Impact Trajectory

Stopping Distance 250 ft downstream
 4 ft left of center

Test Article Debris Scatter

Longitudinal 95 ft
 Lateral 48 ft

Vehicle Damage

VDS 12FL1
 CDC 12FLEN1
 Max. Exterior Deformation None
 OCDI FL0000000
 Max. Occupant Compartment Deformation None

Figure 6.6. Summary of Results for MASH Test 3-71 at 0° on PSS Anchor® Mast® Type III Barricade.

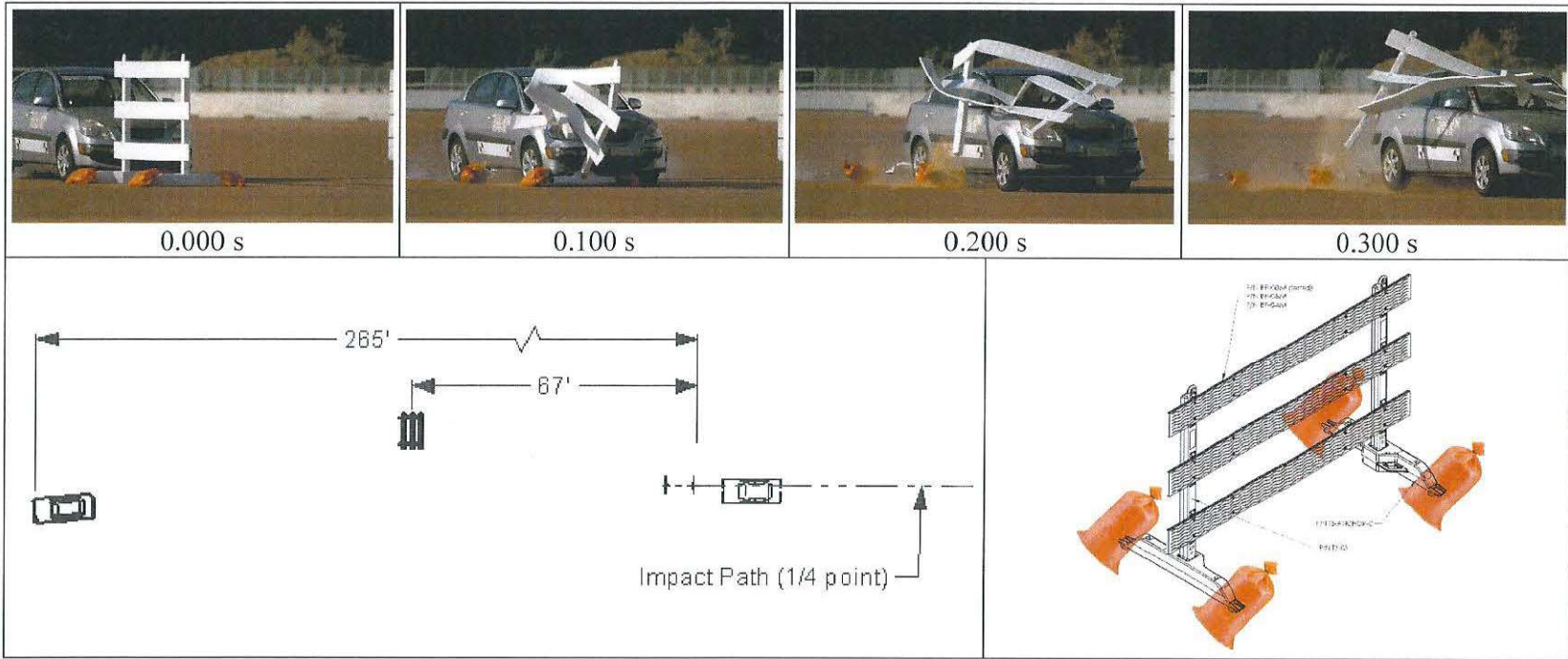

General Information

Test Agency Texas A&M Transportation Institute (TTI)
 Test Standard Test No..... MASH Test 3-71 at 90°
 TTI Test No. 690900-PSS21
 Date 2019-09-13

Test Article

Type Type III Barricade
 Name PSS Anchor® Mast® Type III Barricade
 Installation Dimensions..... 96 inches wide x 47.6 inches long x 64.4 inches tall
 Material or Key Elements..... Three horizontal wave boards supported by a pair of Mast® upright posts and Anchor® base feet

Soil Type and Condition Placed on concrete surface, dry

Test Vehicle

Type/Designation 1100C
 Make and Model 2009 Kia Rio
 Curb 2455 lb
 Test Inertial 2438 lb
 Dummy 165 lb
 Gross Static 2603 lb

Impact Conditions

Speed 60.3 mi/h
 Angle 90°
 Location/Orientation..... 14 inches right of vehicle centerline

Kinetic Energy (KE) 296 kip-ft

Exit Conditions

Speed 57.3 mi/h
 Angle 90°

Post-Impact Trajectory

Stopping Distance 265 ft downstream
 6 ft left of center

Test Article Debris Scatter

Longitudinal..... 67 ft
 Lateral 12.5 ft

Vehicle Damage

VDS 12FR1
 CDC 12FREN1
 Max. Exterior Deformation 0.25 inches
 OCDI FR0000000
 Max. Occupant Compartment Deformation..... None

Figure 5.6. Summary of Results for MASH Test 3-71 at 90° on PSS Anchor® Mast® Type III Barricade.

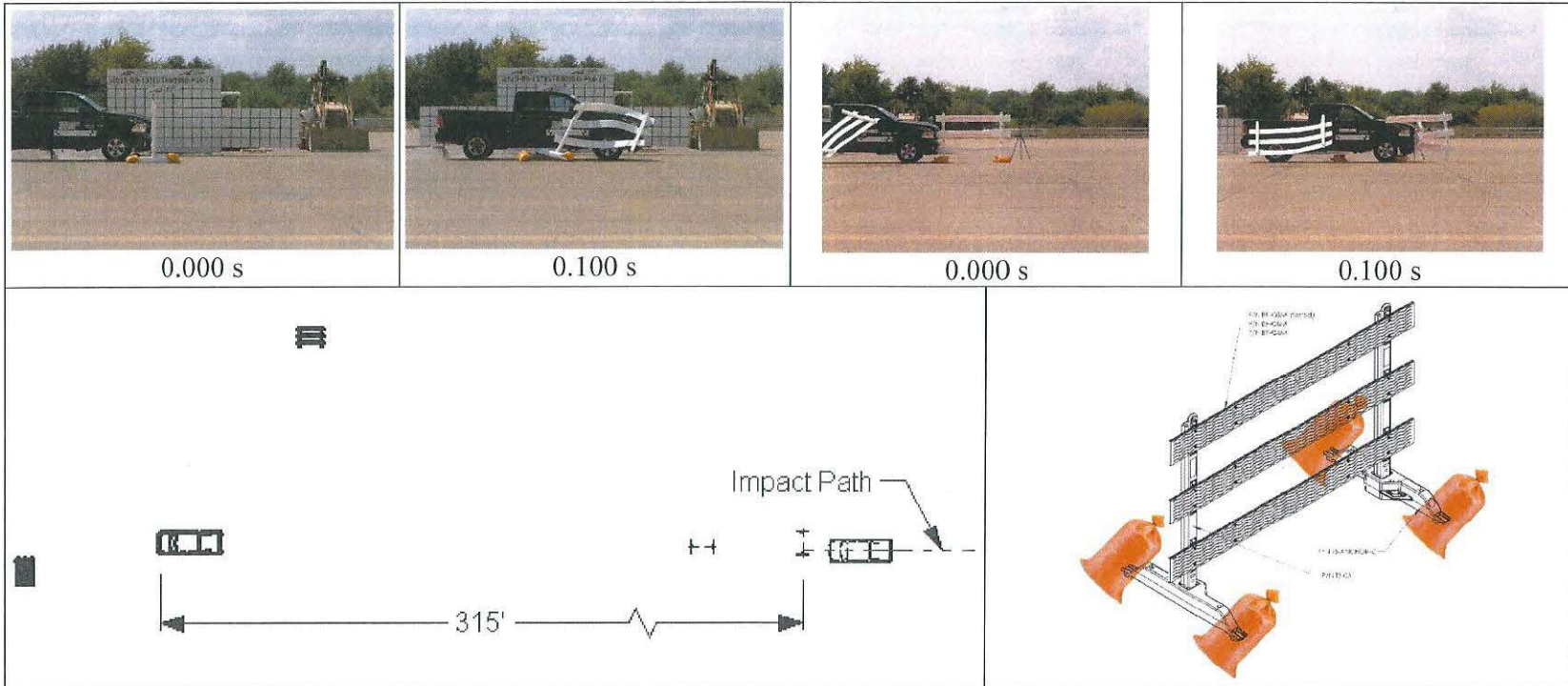

General Information

Test Agency Texas A&M Transportation Institute (TTI)
 Test Standard Test No. MASH Test 3-72 at 0° and 90°
 TTI Test No. 690900-PSS19
 Date 2019-09-13

Test Article

Type Type III Barricade
 Name PSS Anchor® Mast® Type III Barricade
 Installation Dimensions 96 inches wide x 47.6 inches long x 64.4 inches tall
 Material or Key Elements Three horizontal wave boards supported by a pair of Mast® upright posts and Anchor® base feet

Soil Type and Condition Placed on concrete surface, dry

Test Vehicle

Type/Designation 2270P
 Make and Model 2013 RAM 1500
 Curb 4916 lb
 Test Inertial 4996 lb
 Dummy No dummy
 Gross Static 4996 lb

Impact Conditions

Speed 62.3 / 61.3 mi/h
 Angle 0° and 90°
 Location/Orientation Post 12 inches toward drivers
 12 inches to passengers

Kinetic Energy (KE) 648 kip-ft

Exit Conditions

Speed after second unobtainable
 Angle NA

Post-Impact Trajectory

Stopping Distance 315 ft downstream

Test Article Debris Scatter

Longitudinal 355 ft
 Lateral 71 ft

Vehicle Damage

VDS 12FR1
 CDC 12FREN1
 Max. Exterior Deformation None
 OCDI FR0000000
 Max. Occupant Compartment Deformation None

Figure 7.7. Summary of Results for MASH Test 3-72 at 0° and 90° on PSS Anchor® Mast® Type III Barricade.

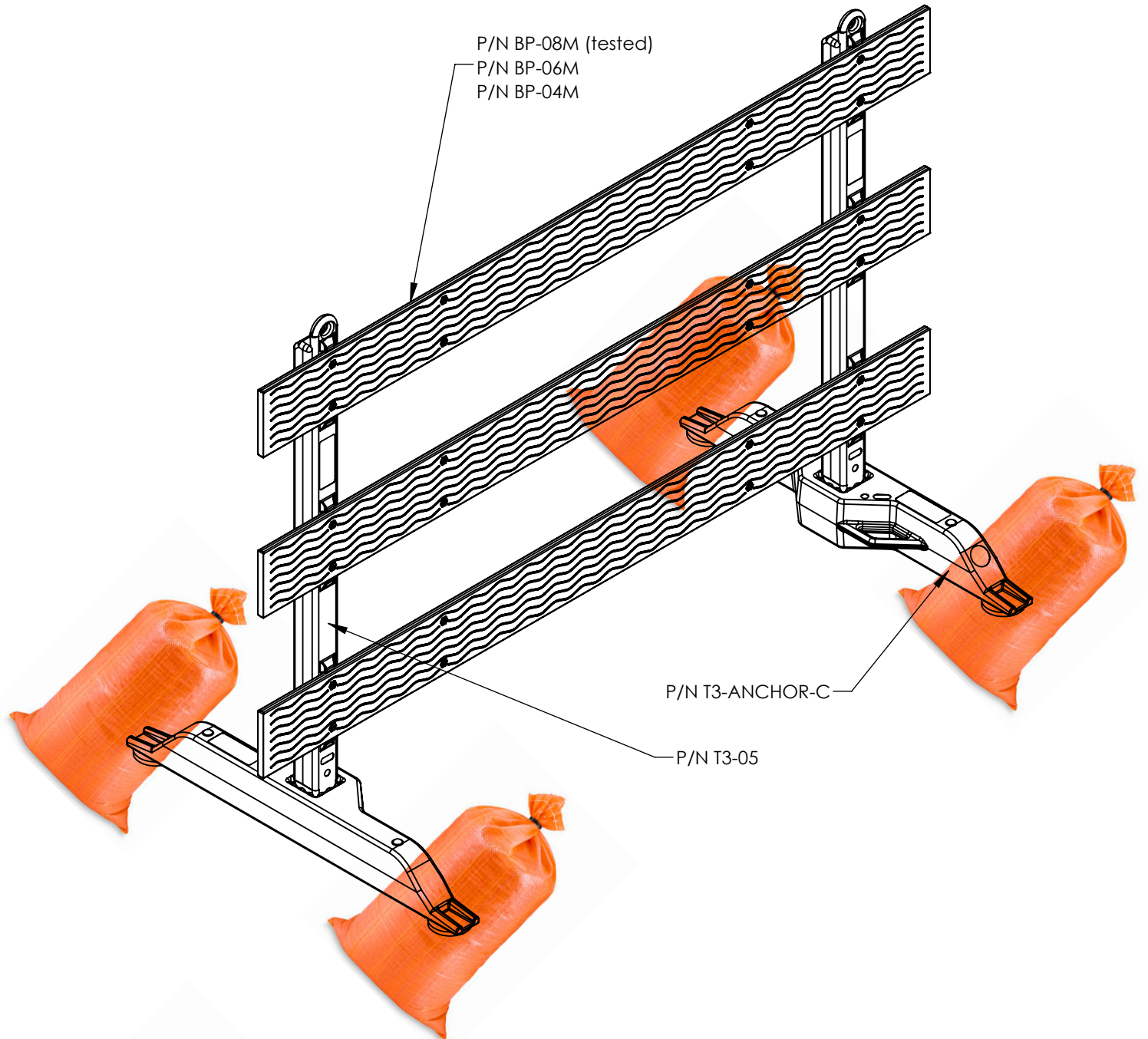

Signifies location of 50 lbs sandbag. 4 sandbags total; 2 placed on ends of each leg.

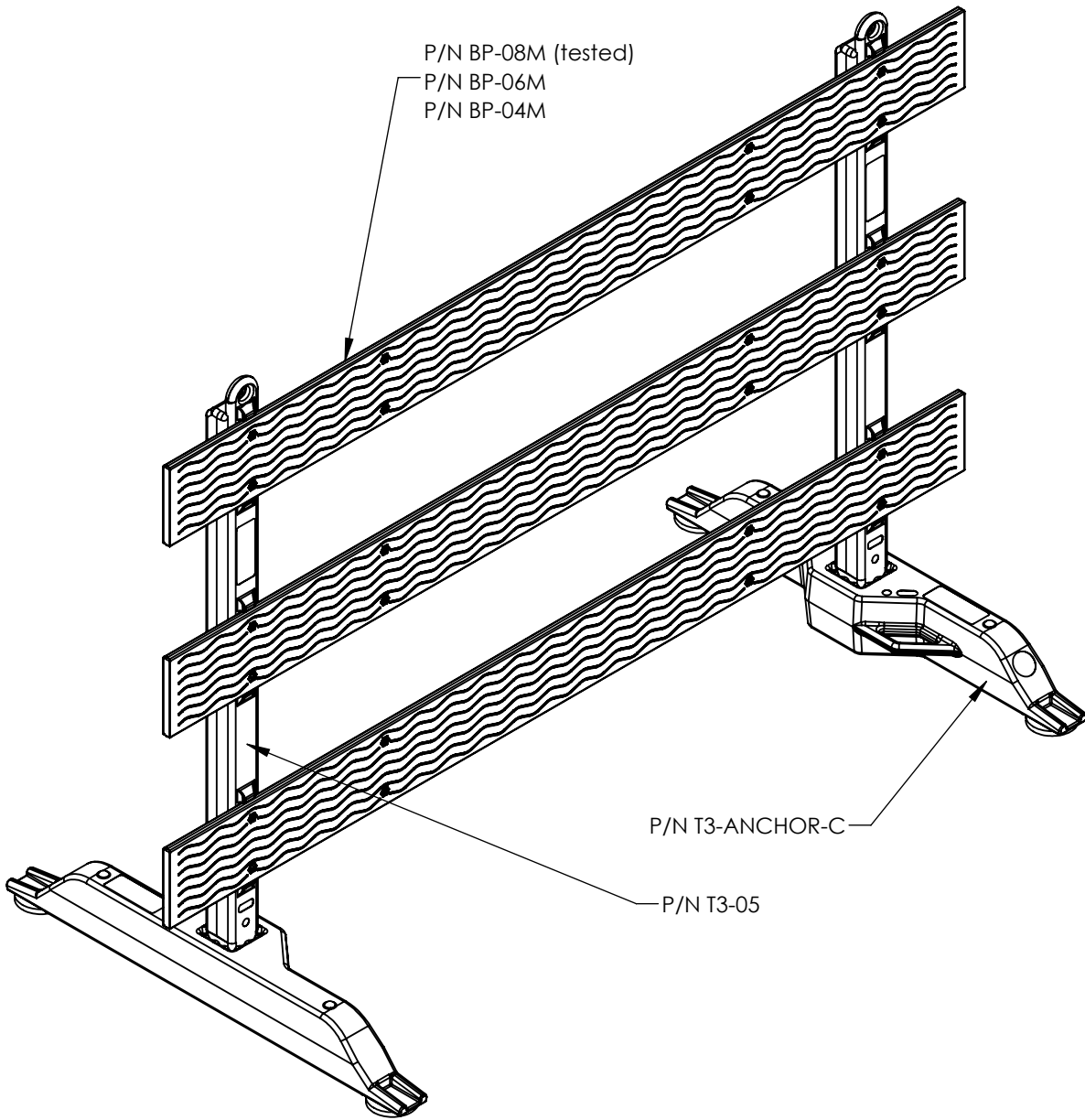

Notes: Previous Acceptance NCHRP-350 TL-3 WZ-152
 Ballast each Anchor Foot internally with up to 45 lbs. of sand or use a Maximum of (2) 50 lb sand bags per foot.

Anchor / Mast Type-III Barricade

PSS

XXXXX

Sheet No.	Date
1 of 3	6/6/19

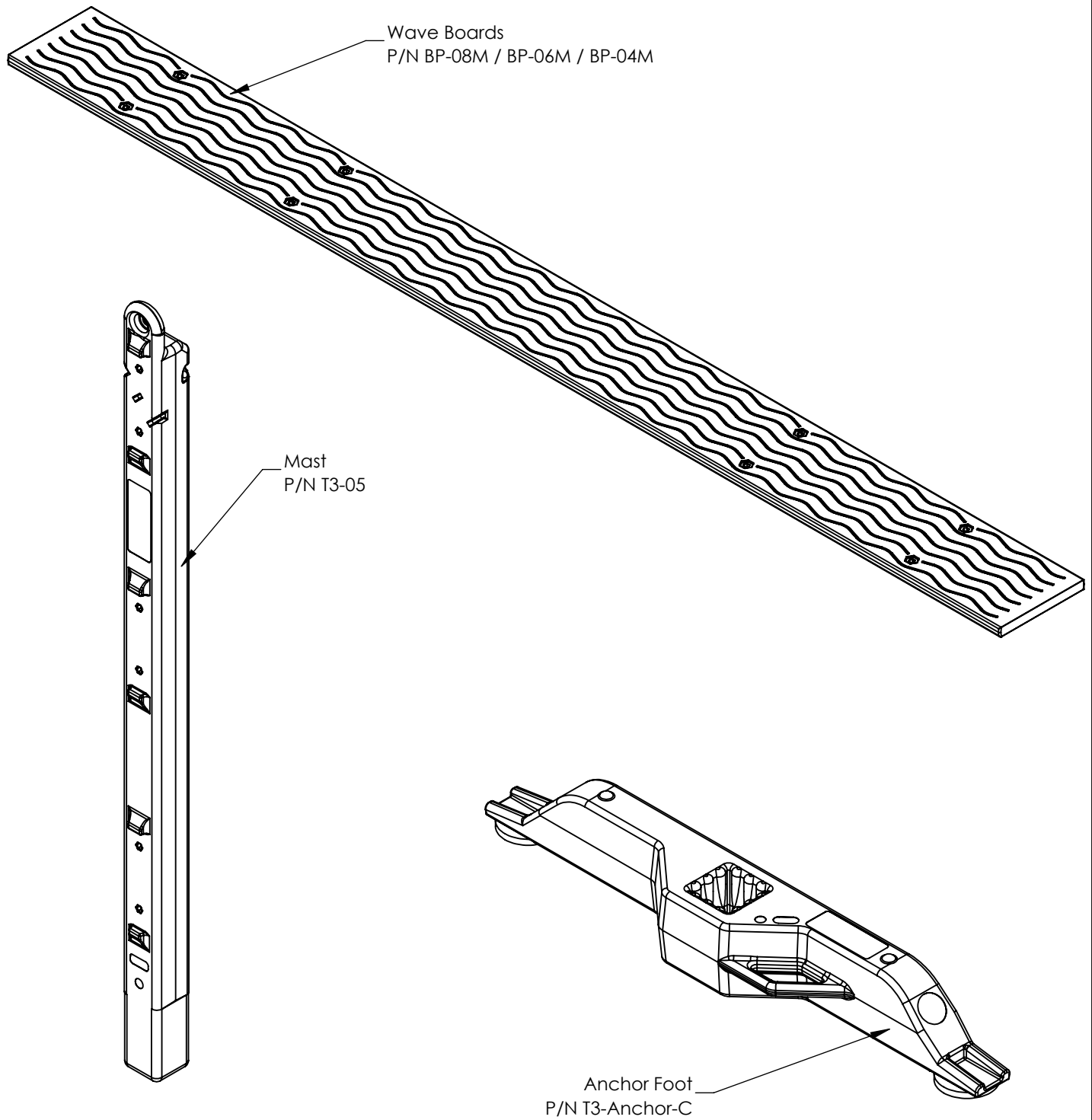

Anchor / Mast Type-III Barricade

PSS

XXXXXX

Sheet No.

Date

2 of 3

6/6/19

INTENDED USE

Anchor / Mast Type-III Barricade. Anchor / Mast Type-III Barricade consists of (2) Anchor Feet (P/N T3-Anchor-C) Mast Up-rights (P/N T3-05) and Barricade rails made from 4' or 6' or 8' (BP-04M / BP-06M / BP-08M) Wave Boards (WZ-173). Wave Boards can be sheeted with Retroreflective material as required.

Approvals:

MASH Acceptance - Pending

NCHRP-350 Acceptance WZ-152

https://safety.fhwa.dot.gov/roadway_dept/countermeasures/reduce_crash_severity/workzone/pdf/wz152.pdf

Contact Information

PSS
2444 Baldwin Road
Cleveland, Ohio 44104
Telephone (216)231-8590
Fax (216)213-2702
www.pss-innovations.com

Anchor / Mast Type-III Barricade

PSS

XXXXXX

Sheet No.

Date

3 of 3

6/6/19

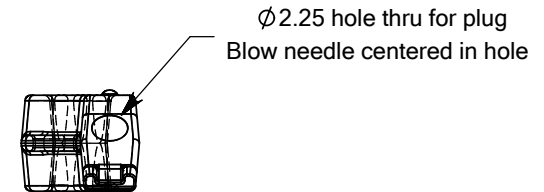
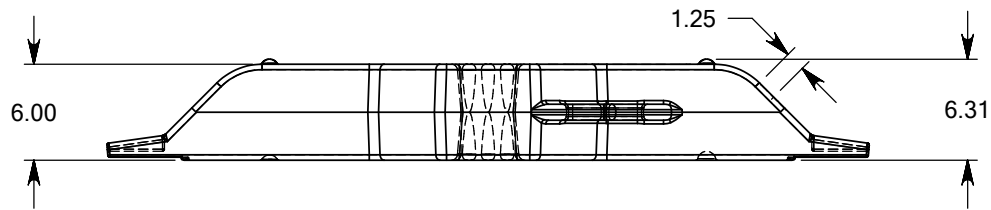
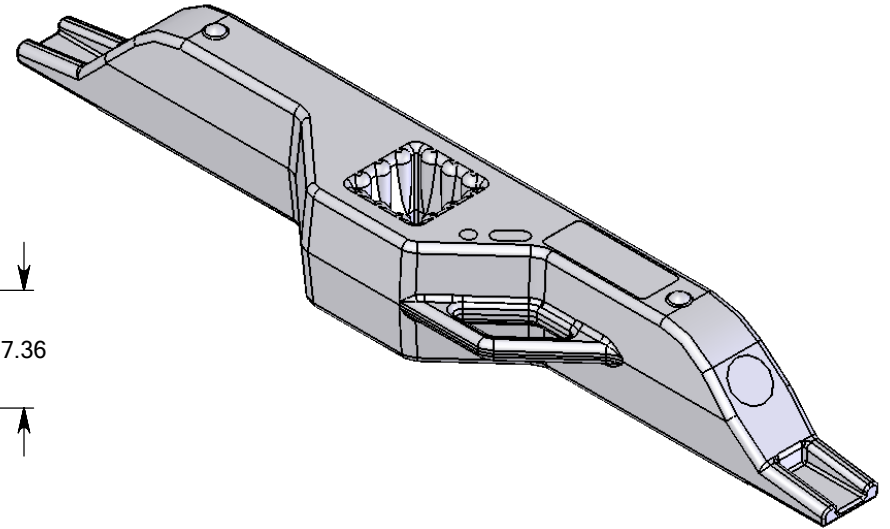
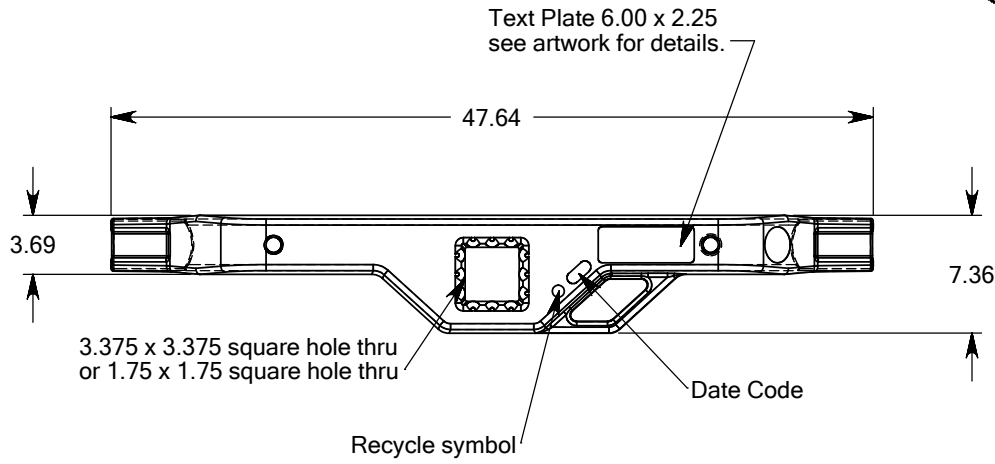

Note: Material: HDPE - White
 General Color #G8Y-3736-U or approved equivalent.
 Part weight 5.75 lbs MINIMUM. Wall thickness 0.140" MINIMUM
 except for within 2" of thru hole 0.080" MINIMUM.
 Date code must be correct and legible.
 Trim flash must be less than 0.015"
 Spin Pads must be installed on both ends with 2 staples each.
 Staples must be folded correctly.
 Plug RT-20 to be installed up to second rib.

PROPRIETARY AND CONFIDENTIAL
 THE INFORMATION CONTAINED IN THIS
 DRAWING IS THE SOLE PROPERTY OF
 Plastic Safety Systems Inc. ANY
 REPRODUCTION IN PART OR AS A WHOLE
 WITHOUT THE WRITTEN PERMISSION OF
 Plastic Safety Systems, Inc. IS
 PROHIBITED.

		DIMENSIONS ARE IN INCHES TOLERANCES: FRACTIONAL ± 1/16 ANGULAR: MACH ± 2° TWO PLACE DECIMAL ± 0.032 THREE PLACE DECIMAL ± 0.015		NAME CMM	DATE 9/18/06	Plastic Safety Systems		
		MATERIAL HDPE		CHECKED				Anchor - 48"
		FINISH N/A		ENG APPR.		SIZE A	DWG. NO. Anchor-48	
NEXT ASSY	USED ON	APPLICATION DO NOT SCALE DRAWING		MFG APPR.		SCALE:1:12	WEIGHT:	SHEET 1 OF 1
				Q.A.				
				COMMENTS:				

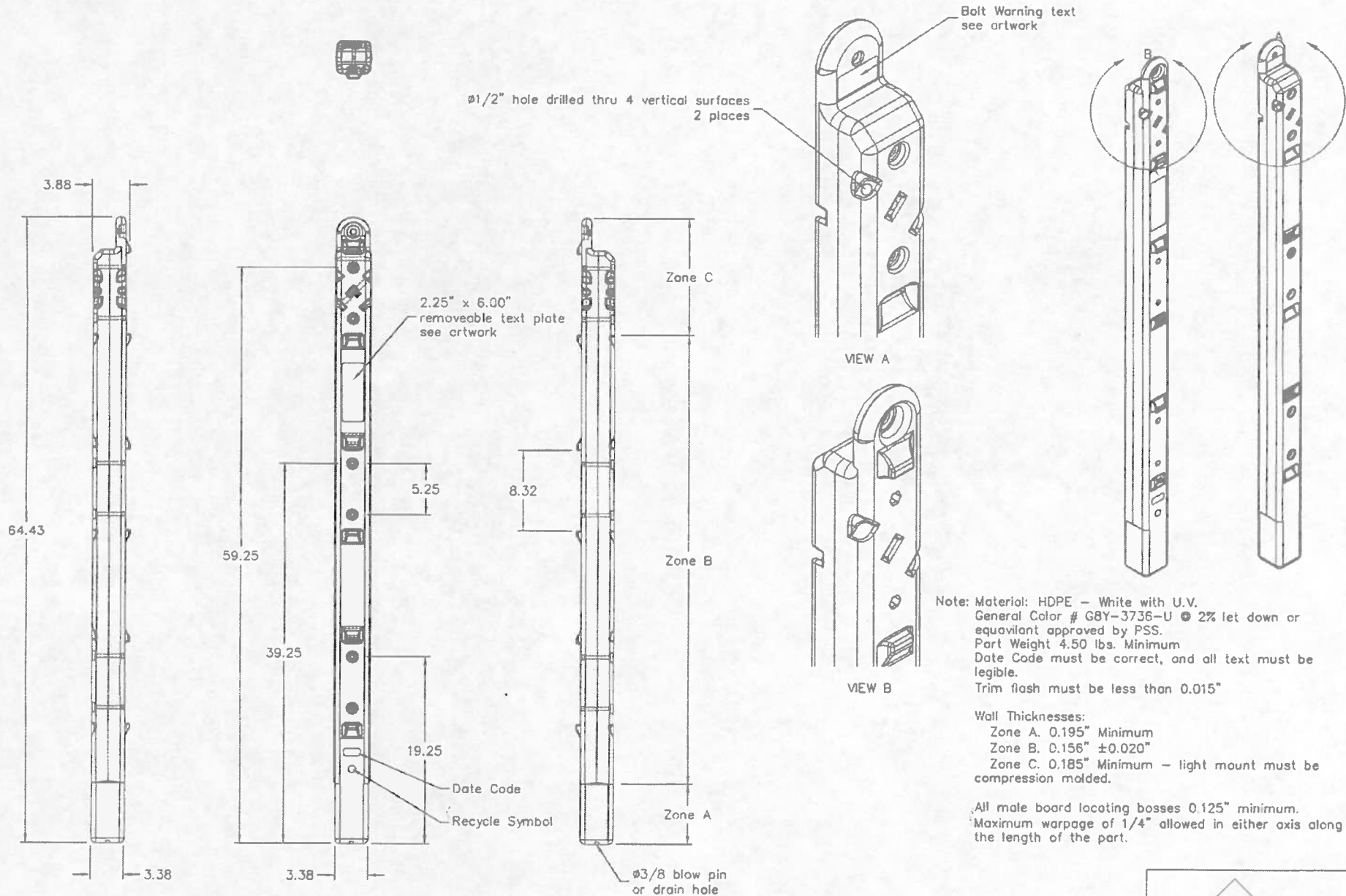

Note: Material: HDPE - White with U.V.
 General Color # G8Y-3736-U @ 2% let down or equivalent approved by PSS.
 Part Weight 4.50 lbs. Minimum
 Date Code must be correct, and all text must be legible.
 Trim flash must be less than 0.015"

Wall Thicknesses:
 Zone A. 0.195" Minimum
 Zone B. 0.156" ±0.020"
 Zone C. 0.185" Minimum - light mount must be compression molded.

All male board locating bosses 0.125" minimum.
 Maximum warpage of 1/4" allowed in either axis along the length of the part.

This drawing is property of Plastic Safety Systems, Inc. and is furnished with the understanding that the recipient agrees that he will consider confidential and will not divulge, reproduce, copy or otherwise dispose of the same, directly or indirectly, and will not use the drawing in whole or in part to assist in making or furnish exact or similar facimiles thereof, in any way, except upon written permission of Plastic Safety Systems, Inc. The review or acceptance of this drawing will be construed as acceptance of the foregoing statement.

E		
D		
C		
B		
A		
REV	Date	Description

Material: See note		Date: 2/23/05	By: CMM	File: MAST-QC
Sheet: 1 of 1	Scale: Full	Title:		
Tolerances unless noted: .00 ± 0.030		Most 5' molded up-right QC specifications		
.01 ± 0.010				
fractions ± 1/16				
angles ± 2'				



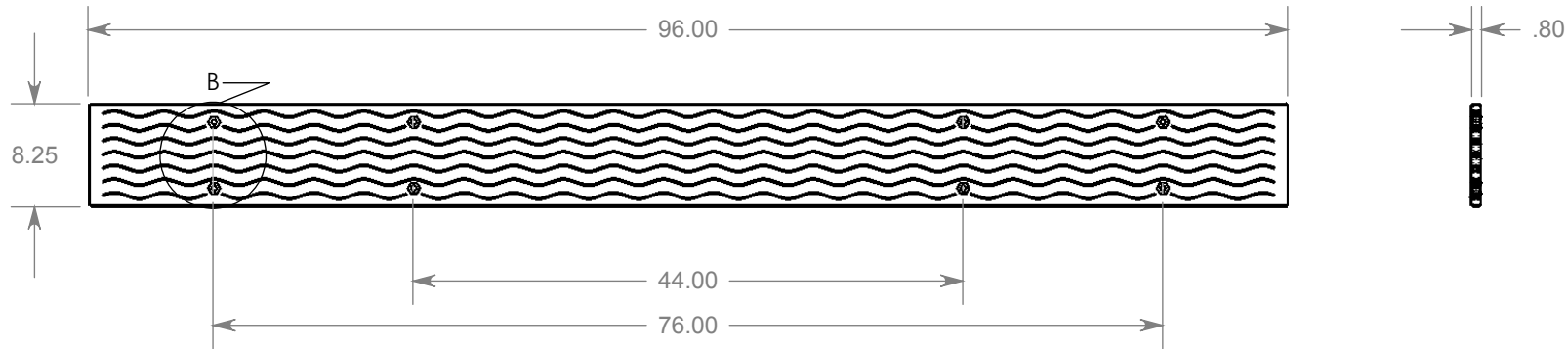
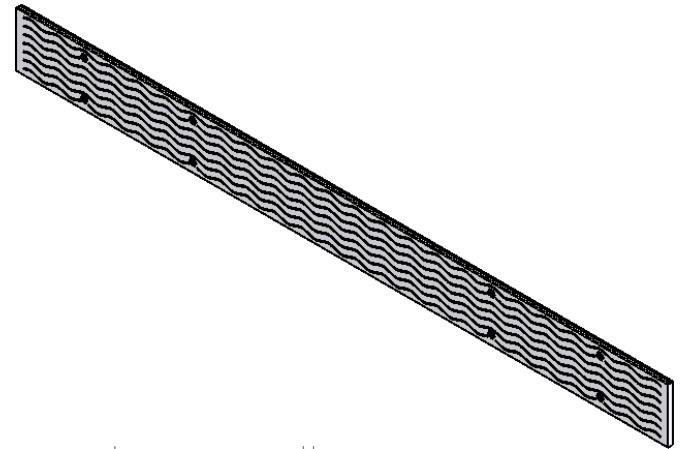
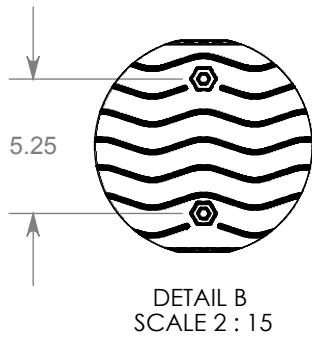

- Notes:
- Material - HDPE, White - General Color #G8Y-373-U, 2% let-down.
 - (B) Part Weight - 0.52 lbs / foot Minimum.
 - (C) Minimum Wall Thickness 0.045" Except for 3" from each end 0.060" Minimum.
 - Modular tool to make 48" / 72" / 96" lengths. 4' & 6' parts to have holes 44" on center. 8' part to have holes 44" & 76" on center.
 - (B) Trim Flash must be less than 0.005"
 - Hole slugs must be completely removed from part.
 - Parts must be clean and free of grease, oil, dust and dirt.
 - Maximum warpage 3/8"
 - All text - Logos & Date Codes must be legible.

PROPRIETARY AND CONFIDENTIAL
 THE INFORMATION CONTAINED IN THIS DRAWING IS THE SOLE PROPERTY OF Plastic Safety Inc. ANY REPRODUCTION IN PART OR AS A WHOLE WITHOUT THE WRITTEN PERMISSION OF Plastic Safety Inc. IS PROHIBITED.

		UNLESS OTHERWISE SPECIFIED:		NAME	DATE
		DIMENSIONS ARE IN INCHES	DRAWN	CMM	7/20/09
		TOLERANCES:	CHECKED		
		FRACTIONAL ±	ENG APPR.		
		ANGULAR: MACH ± BEND ±	MFG APPR.		
		TWO PLACE DECIMAL ±	Q.A.		
		THREE PLACE DECIMAL ±	COMMENTS:		
		INTERPRET GEOMETRIC TOLERANCING PER:			
		MATERIAL			
NEXT ASSY	USED ON	FINISH			
APPLICATION		DO NOT SCALE DRAWING			

Plastic Safety Systems, Inc.		
TITLE: Wave board QC standards		
SIZE A	DWG. NO. Wave-QC	REV C
SCALE: 1:15	WEIGHT:	SHEET 1 OF 1